

ORISSA SYNCHRODEX

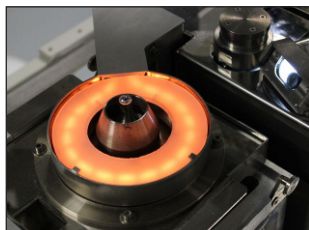

Pillarhouse
INTERNATIONAL

Flexible, in-line, modular selective soldering system

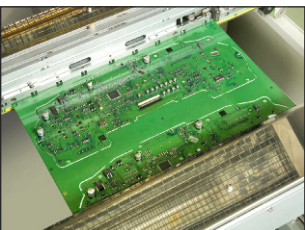

ORISSA SYNCHRODEX

Flexible, in-line, modular selective soldering system



Designed as a modular system, the Synchrondex range of in-line equipment offers the ultimate in flexibility with the ability to upgrade to high speed throughput when multiple modules are placed together.

Supplied as standard with our patented design Drop-Jet fluxer, this system offers accurate, controlled flux deposition either prior to or during the optional top side preheat function. Preheat can be controlled via an optional top-side closed loop pyrometer system for optimum temperature profile regulation.

Our low maintenance solder bath and pump mechanism moves in three axes. Solder is applied using our proven technology single point AP nozzle design incorporating patented spiral solder return to bath technology offering increased wave stability with reduced potential for solder balls. The system can also accommodate our latest generation micro nozzle, together with Jet-Wave, Wide-Wave and dedicated multi-tube single dip solder technology.

As with all Pillarhouse systems, the soldering process is enhanced by a hot Nitrogen curtain which provides an inert atmosphere for the soldering process and also assists in the prevention of oxidation. This process provides a local preheat to the joint thus reducing thermal shock to localised components.

The Synchrondex is controlled by a PC, through PillarCOMM, a Windows® based 'Point & Click' interface with PCB image display. Additionally, our PillarPAD offline package allows the operator to produce programs independently from the machine using Gerber data.



JET-TIP NOZZLE

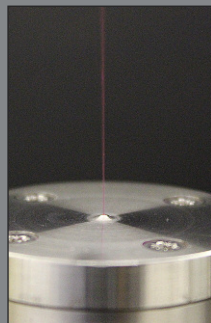

DROP-JET FLUX HEAD



150MM WAVE NOZZLE



TOP-SIDE PREHEAT OPTION

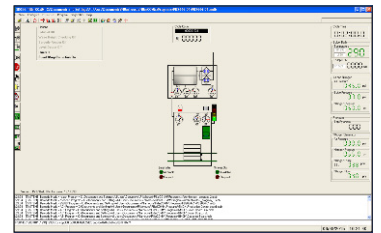

OPERATION

The Synchrondex is controlled by a PC, through PillarCOMM, a Windows® based 'Point & Click' interface with PCB image display, as illustrated above. Additionally, our PillarPAD offline package allows the operator to produce programs independently from the machine using Gerber data.

PILLARGEN-80

Nitrogen generation system



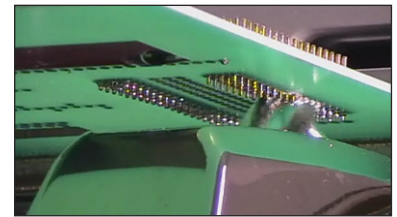

JET-WAVE SOLDER NOZZLE



TWIN FIXED PITCH AP SOLDER
NOZZLE

STANDARD FEATURES

- In-line motor driven auto width adjust
- through feed synchronous movement conveyor
- Conveyor side clamping
- Integral PC and machine mounted TFT monitor
- Auto solder wire feed and level detect
- Heated inerted Nitrogen system
- Drop-Jet fluxer
- Set of AP solder nozzle tips
- Internal fume extraction
- Solder wave height measurement and correction system
- Colour programming camera
- Windows® based PillarCOMM 'Point & Click' interface
- Light stack
- Fiducial recognition and correction system
- Flux level sensor
- Multiple level password protection
- PillarPAD offline programming system
- SMEMA compatible
- Process viewing camera with record feature
- Lead-free capability
- Day-to-day service kit

MONITORING OPTIONS

- Flux presence sensor - thermistor style
- Flux spray, flow and spray & flow
- Pump rpm
- O₂ ppm
- Nitrogen flow

OPTIONS

- Ultrasonic fluxing
- Dual Drop-Jet / ultrasonic fluxing
- Top-side instant IR preheat
- Closed loop pyrometer temperature control
- Bottom-side hot Nitrogen selective preheat
- Laser PCB warp correction
- Solder reel identification
- Solder bath coding - identifies correct bath for program
- Encoders on X, Y and Z axis
- Nitrogen generator

ORISSA SYNCHRODEX



Pillarhouse
INTERNATIONAL

SPECIFICATIONS

Height:	1615mm / 63" - excluding light stack
Width:	813mm / 32"
Depth:	2024mm / 80"
Board size:	Max. - 457mm x 610mm / 18"x 24" Min. - 102mm x 102mm / 4"x 4"
Edge clearance:	Above/below 3mm
Height clearance:	Below 40mm - above 45mm 100mm - upon request
Extraction:	Fan: 276mm dia.
Rating:	1000m ³ /hr / 589 CFM
Solder:	Most commonly used solder types - including lead-free
Solder pot capacity:	15kg standard - 25kg large bath
Applicators:	AP style - 2.5 - 16mm dia. Extended and Jet-Tip nozzles - up to 25mm dia. Jet-Wave nozzles - up to 25mm width 150mm Wave nozzle
Flux:	Low maintenance Drop-Jet system. Low solids (below 8%), no clean flux, pressurised and inerted system, optional water-soluble system available
Flux tank capacity:	1 litre
Fluxer speed:	50 dots/second
Deposition size:	4.0-6.0mm / 0.16-0.24"
X, Y & Z axis resolution:	0.15mm
Repeatability:	+/- 0.05mm
Nitrogen supply pressure:	5 bar / 72 psi
Nitrogen usage:	30-100 litres/min. - solder nozzle configuration dependent
Nitrogen purity:	99.995% or better
Air supply pressure:	5 bar / 72 psi
Air usage:	10 litres/min. / 0.35 CFM
Power Supplies:	Single phase + PE
Voltage:	230V
Frequency:	50/60Hz
Power:	10.5 kVA max. - machine configuration dependent
Transport:	Conveyor
Programming:	PillarCOMM Windows® based 'Point & Click' interface

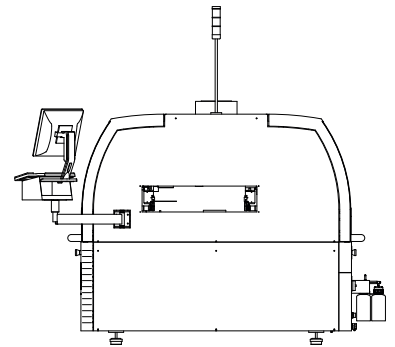
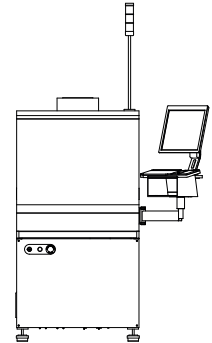

Pillarhouse International Ltd.
Rodney Way, Widford, Chelmsford, Essex CM1 3BY UK
Pillarhouse USA, Inc.
201 Lively Blvd, Elk Grove Village, IL 60007 USA
Pillarhouse (Suzhou) Soldering Systems Co., Ltd.
11 Yuanqi Road, Xiangcheng, Suzhou, China 215131

www.pillarhouse.co.uk
Tel: +44 (0) 1245 491333 Fax: +44 (0) 1245 491331
www.pillarhouseusa.com
Tel: +1 847 593 9080 Fax: +1 847 593 9084
www.pillarhouse.cn
Tel: +86 512 6586 0460 Fax: +86 512 6959 0567