

Coating equipment for liquid material Joint surface coating equipment for liquid gasket

Introduction

The growing popularity of single-use liquid gaskets has increased demand for automated coating from various industries.

Conventional liquid gaskets were used together with solid gaskets and tended to play mere auxiliary roles. Therefore, they were low viscosity to allow easy manual application using simple tools such as brushes, spatulas, or rollers.

Gasket materials intended for single use demand high sealing performance and high initial pressure resistance with film growth. This means a thick film, which requires high viscosity, which in turn makes manual coating more difficult and decreases productivity. For these reasons, these years pressing demand has emerged for high productivity coating equipment to mechanize the liquid gasket coating process on mass production lines. But while mechanization of other assembly processes has advanced significantly, mechanization in this particular field lags far behind. Liquid gaskets as a group have various types, according to the use targets, including organic solvent, aqueous, anaerobic, and silicone types. The design and development of suitable coating equipment require understandings of characteristics for individual viscous fluids. And with

the combination of types of gasket materials, applications, line characteristics, and user approaches, the form of equipment has too many variations and demands exclusive equipment for each case. It makes difficult to standardize designs for liquid gasket coating equipment. There are few dedicated manufactures of this kind of equipment because considering after services, such equipment business is not justifiable.

Only two or three specialized manufacturers are in business even in the United States, an advanced country of FIPGs (Formed In Place Gaskets) utilizing silicon type liquid gaskets. However, such American equipment is most unlikely applicable for mass production lines in Japan without any difficulties.

Such lack of comprehensive manufacturers of coating equipment has caused the delay of mechanization, however, single use of liquid gasket is expected to bring significant cost reduction and improvement of sealing performance. Therefore, from the users point of view, development of coating equipment is urgently required.

In this issue, as a special manufacture of liquid gasket, we will introduce the coating technique we have researched more than 10 years, and we hope this article helps all levels of users in this regard.

Contents

Introduction.....	1	4. Screening method.....	11
1. Types and properties of liquid gaskets.....	2	4-1 Configuration of screening-type coating equipment.....	11
2. Types and characteristics of coating equipment.....	2 to 3	4-2 Standard specifications for screening method.....	11
3. Tracing method.....	4	5. Stamping method.....	12
3-1 Various components required for the tracing method ...	4	5-1 Stamping method procedure.....	12
3-2 Nozzle-driving methods and a comparison.....	5 to 6	5-2 General specifications for stamping method.....	12
3-3 Various pressure feed methods for supplying material and associated characteristics.....	6 to 8	6. Examples of actual coating equipment applications.....	13
3-4 Valve types and characteristics.....	8 to 9	Product Introduction: Pando Series.....	14
3-5 Non-standard component types and characteristics...	10	Completion of the Three Bond Research Center.....	16

1. Types and properties of liquid gaskets

This section describes points of properties to be considered for designing coating equipment, rather than the intrinsic nature of liquid gaskets.

Table 1

Properties		Type	Volatile type		Reactive type	
			Organic solvent type	Aqueous type	Silicone type	Anaerobic type
Nature	Ordinary state	Viscous fluid	Viscous fluid	Paste-like	Paste-like	
	Viscosity	2,000 to 10,000 cps	2,000 to 20,000 cps	50,000 to 300,000 cps	40,000 to 200,000 cps	
Solidification	Factor	Volatilization of organic solvent	Volatilization of water	Reaction with moisture or water	Interception of Oxygen	
	Speed	In normal air ambient Film is formed in 3 to 10 minutes	← Film is formed in 5 to 10 minutes	← Film is formed in 3 to 10 minutes	← Not to solidify	
Characteristics	Source of pressure feed	Low viscosity Pneumatic pressure tank	←	High viscosity High-pressure pump Cartridge tank	Non-fluid Metallic contact is not permitted Cartridge tank	
	Material for liquid contacting part	Select resistive materials to organic solvents.	Select resistive material to water.	Select materials of non-water-absorbent and non-air-permeable.	Select materials of air-permeable.	
	Re-dissolution after solidified	Dissolvable by organic solvent.	Non-dissolvable.	←	←	
	Precipitation	Type dependent	A certain degree of precipitation occurs.	No precipitation occurs.	No precipitation occurs.	
	Cleaning agent for uncured material	Organic solvent	Water	Triol	Organic solvent	
	Wear of sliding parts	Type dependent	No wear occurs.	Type dependent	No wear occurs.	
Applications	Motorcycles	Lower case Cylinder head (combined use)		Cylinder head	Crank case	
	Automobiles	Steering gear box, brake cover, and transmission case		Oil pan Oil pump	Transmission case	
	Other	Gas meter cover		Bathroom vanity	Pump case	

2. Types and characteristics of coating equipment

In case coating liquid gasket to joint surface, there two coating methods, point coating (including multi-point coating) and line coating, exist. Because point coating is the one that is simplified line coating, it will be omitted here. Excepting extremely special cases, coating equipment is classified in following three types:

Table 2

Type of coating	Tracing method	Screening method	Stamping method
Overview	Gasket material fed from the pressure feeder through the feeder pipes is dispensed from the nozzle tip in string form. The material is applied as a line on the surface by moving the nozzle parallel to the surface.	Gasket material is placed on the screen that masks the patterns not to be printed, and the joint surface is set under the screen. The material is then squeezed down through the opening by a squeegee.	A box-type drum is rotated in a liquid bath to form a film of certain thickness on the drum surface. The joint surface is then pressed against the drum surface to transfer the film for coating.
Applicable gasket materials	Solvent type, aqueous type, silicone type, and anaerobic type	Anaerobic type	Solvent type and aqueous type
Features	Applicable for three dimensional surface coating Applicable to all types of gasket materials Allows easy adjustment of coating amount. Can be integrated into automated lines.	High coating speed. High dimensional accuracy of coating pattern. Allows thin film coating. Can be integrated into automated lines.	High coating speed. No restrictions on complexity of coating surface or surface width. Allows thin film coating. Good maintainability

Type of coating	Tracing method	Screening method	Stamping method
Automatic coating equipment types	Following four types available according to differences of nozzle drive type: 1. Template type 2. Photoelectric tube type 3. Computer-controlled type 4. Disk type	Coating operations can be automated by driving the squeegee automatically.	Joint surface exists. This cannot be said as perfect automated coater since the object to be coated must be handed manually for transfer. Therefore, this is semi-automatic coater.
Manual coating equipment types	There is a type which coating is performed by manually moving a hand-gun along the joint surface. 1. Cartridge gun (Photo 1) 2. Cartridge tank and flow gun (Photo 2) 3. Pressure tank and pencil gun (Photo 3) 4. High-pressure pump and flow gun (Photo 4)	In one type, coating is performed by manually operating squeegee.	

Coating equipment with tracing method

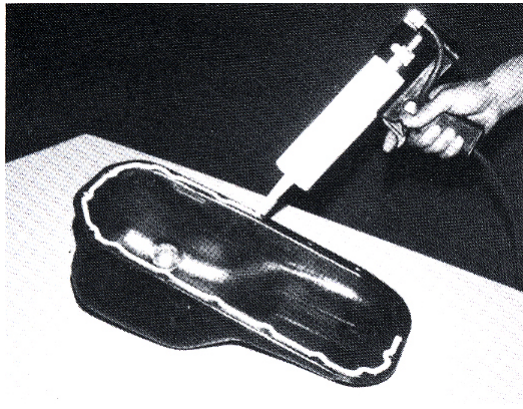

Photo 1. Cartridge gun

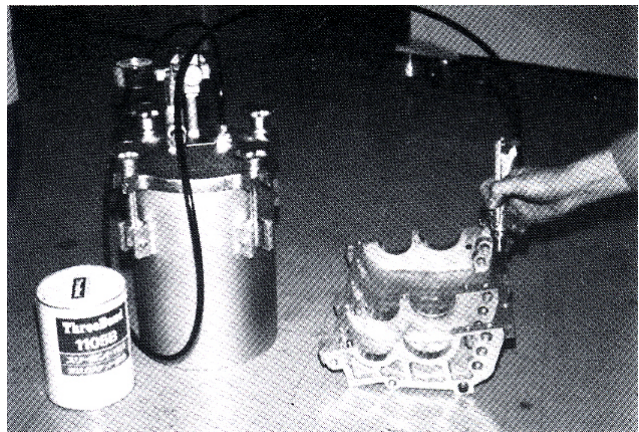

Photo 3. Pressure tank and pencil gun

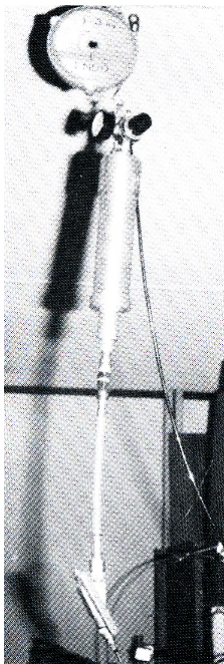

Photo 2. Cartridge tank and flow gun

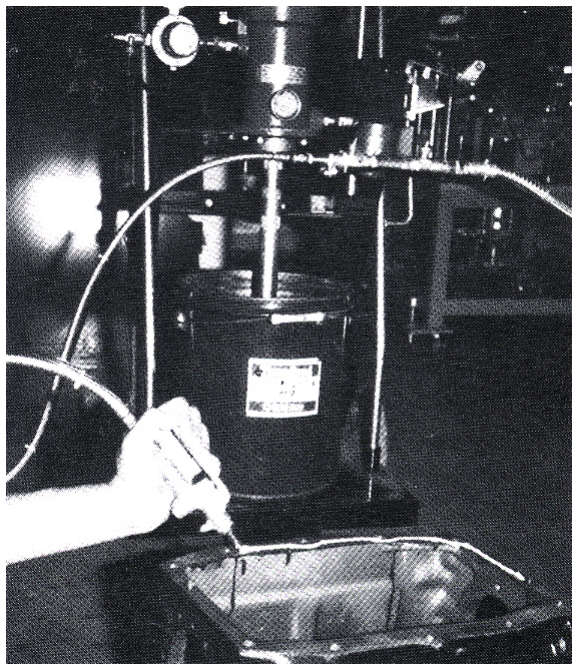

Photo 4. High-pressure pump and flow gun

3. Tracing method

3-1 Components of tracing method

Table 3

Position	Standard components	Non-standard components
Main body stand	<ul style="list-style-type: none"> • Stand: caster, level adjusting bolt • Jigs: work piece positioning pin, coarse guide • Covers • Suspension arm for hoses • Solidification prevention cap for nozzle 	Safety cover, shutter, door, Detectors for work piece presence and machine type Work piece orientation detector Work piece loader and unloader
Nozzle - driving section	<ul style="list-style-type: none"> • Template type Template, magnet roller, electromagnetic coil, universal arm, bevel gear, and induction motor • Photoelectric tube type Photoelectric tube control unit, photoelectric lamp, XY table with DC servo motor, nozzle-mounting arm. • Computer-controlled type XYZ orthogonal table with DC servo motor, rotary encoder, bellows-type dust cover • Disk type Disk, spur gear, induction motor 	Automatic template switching mechanism
Head section	<ul style="list-style-type: none"> • Valve for coating material • Nozzle block and nozzle • Nozzle lifting and lowering device 	Flow control valve Shock sensor Solidification prevention cap for nozzle
Pressure feed section	<ul style="list-style-type: none"> • Pressure feeder Pressure tank: air pressure regulator Cartridge tank: air pressure regulator High-pressure pump: air pressure regulator Mounting mechanism for the coating material container • Pressure feeder pipes For low pressure: nylon or Teflon tube For high pressure: SUS-braided Teflon tube • Relay block or distributor 	Residue detector Material regulator Material filter Tank pressure compensator device Stirrer
Control section	<ul style="list-style-type: none"> • Electrical control Master control panel, secondary control panel Operating panel Switch box for start-up and emergency stop • Pneumatic control Cocks for pressure source: three cocks set Pressure switch Electromagnetic valves 	External memory device Voltage stabilizer

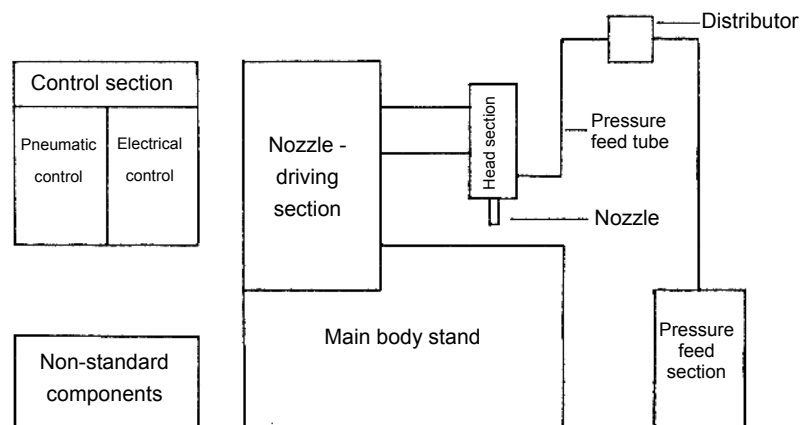

Figure 1. Components required for the tracing method

3-2 Types of Nozzle-driving methods and the comparison

Table 4

		Template type	Photoelectric tube type	Computer-controlled type	Disk type	
Overview		The magnet roller is driven along with template (made of steel) that is cut same as the coating pattern. Coating is performed with the nozzle mounted on the center of the roller. Both the outer periphery and inner periphery of the template may be used.	The photoelectric tube reads the coating pattern drawing drawn on a white paper, and a servo motor mounted on the XY table is driven by the signals from the tube. Coating is performed with the nozzle mounted on the arm that is extended from the XY table..	The computer memorizes the specified coating points and moving conditions of point-to-point movements while the nozzle tip traces the surface of the work piece set at the coating position (playback system). Coating is then performed with playing back the memorized pattern.	A nozzle-driving system used exclusively for circular coating. The nozzle is attached to the circumference of a disk. The disk is rotated with a motor through gears to perform coating in circular patterns.	
		Photo 5	Photo 6	Photo 7	Photo 8	
Specification	Nozzle drive speed	MAX 4 m/minute	MAX 3 m/minute	MAX 12 m/minute	MAX 12 m/minute	
	Partial speed change	Not possible	Not possible	Possible	Not possible	
	Trajectory	Minimum circular arc	6R	6R	5R	50R
		Noncontinuous line	Not possible	Possible	Possible	Possible
		Crossover line	Not possible	Not possible	Possible	Not possible
		Double line	Not possible	Not possible	Possible	Possible
		Three dimension	Not possible	Not possible	Possible	Not possible
	Interchangeability	Method	Plate exchange	Diagram change	Job No. call	Change of nozzle mounting radius
		Time	5 minutes	3 minutes	5 seconds	3 minutes
		Type	Not limited.	Not limited.	20 types (can be increased.)	Not limited.
Reproducibility	±0.1 mm	±0.1 mm	±0.1 mm	±0.1 mm		
Working range	MAX 300 × 500 mm	MAX 300 × 400 mm	MAX 500 × 1000 mm	MAX 600φ		
Features		Tracing method ensures accuracy. Low cost Good maintainability	Excellent pattern interchangeability Allows simultaneous multiple coatings. Low cost	Allows high-speed three-dimensional coating. Excellent pattern interchangeability Allows flexible setting of coating conditions.	Simple and reliable. Low cost Good maintainability	
Applications		Cylinder head cover for motorcycles Transmission case for FF for automobiles Oil pan for automobiles	Gas meter counter case Transmission case for automobiles Caulked section of condenser	Lower case for motorcycles Baffle plate for automobiles Oil pan for automobiles	Differential case for automobiles Mounting portion of wheel drum for automobiles Wheel assembly for automobiles	

Tracing method

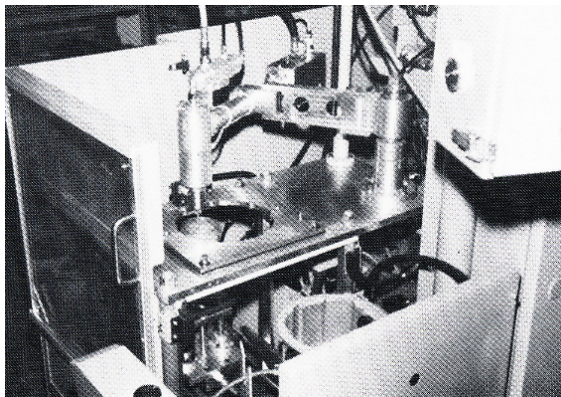

Photo 5. Template type

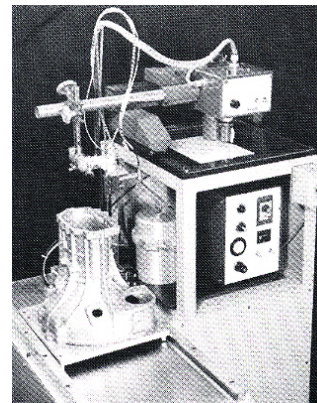

Photo 6. Photoelectric tube type

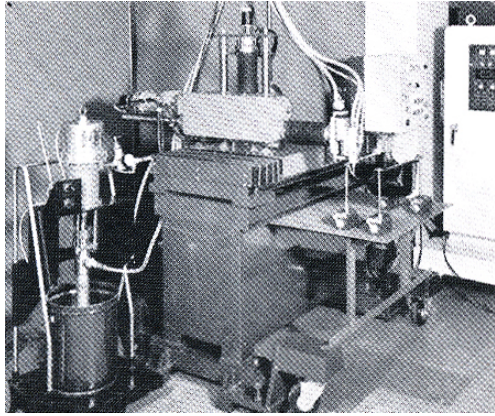

Photo 7. Computer-controlled type

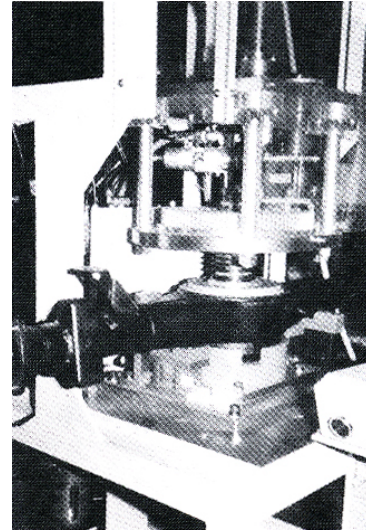

Photo 8. Disk type

3-3 Types of pressure feeder methods and the characteristics

Pressure feeder is material contacting area, and most important portion of coating equipment components, parallel with the valves. Correct selection and handling are essential to avoid problems.

Table 5

Pressure feeder		Pressure tank		Cartridge tank		High-pressure pump	
Type		Direct feed type	Inner container type	Made of plastic	Made of aluminum	Air pump	Power booster
Shape		See Figure 2.	See Figure 3.	See Figure 4.	See Figure 5.	See Photo 9.	
Applicable material		Low-viscosity material (10,000 cps or lower) Organic solvent type, aqueous type, and liquid gaskets		High-viscosity material (10,000 to 300,000 cps) Silicone type and anaerobic type		High-viscosity material (10,000 to 300,000 cps) Organic solvent type and silicone type	
Container capacity		20 L or less, no restrictions on shape		330 cc cartridge		1 L to 20 L, dedicated container	
Applied air pressure		0.5 to 7 kg/cm ²		1.0 to 4 kg/cm ²	1.0 to 6 kg/cm ²	1.5 to 5 kg/cm ²	
Material pressure		Same as air pressure		Same as air pressure		Air pressure × pressure ratio	
Features		Convenient and easy to use Commercially available and easy to obtain Easy cleaning of pipes.		Light weight and compact Can be attached to the head section and driven Low cost		Allows continuous dispensing	No pulsation occurs.
						Possible to achieve high pressure. High-capacity material containers Long replacement intervals	
Pressure feeder hose	Material	Made of nylon or Teflon.		Made of Teflon.		High-pressure Teflon + SUS braid	
	Pressure resistance	30 to 70 kg/cm ²		30 to 70 kg/cm ²		200 kg/cm ²	
	Length	Generally less than 5 m.		Generally less than 1 m.		Generally less than 5 m.	
	Diameter	1/4" to 1/2"		1/4" to 1/2"		1/4" to 1/2"	
Distributor		Made of aluminum and brass.		←		←	
		If distributor is used to operate multiple nozzles, flow-regulating valves are required in order to control dispensing volume individually.					

★ Difference between air pump and power booster

Table 6

Air pump	Power booster
Dual-action type, continuous discharge Always applying pressure Pulsation occurs at the top dead point and bottom dead point. Used as pressure feeder for flow gun.	Single-action type, intermittent dispensing Pressurized only during the dispensing signal No pulsation occurs. Used as pressure feeder for automatic coating equipment with nozzle-driving device.

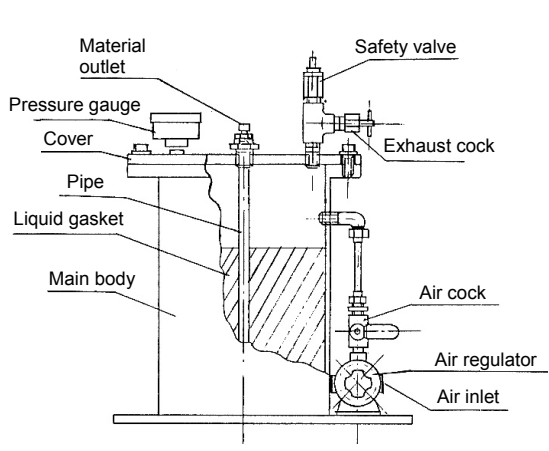

Figure 2. Pressure tank–direct feed type

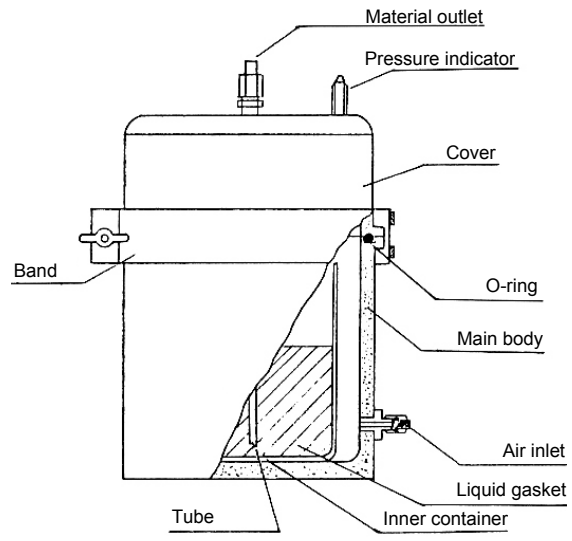

Figure 3. Pressure tank–inner container type

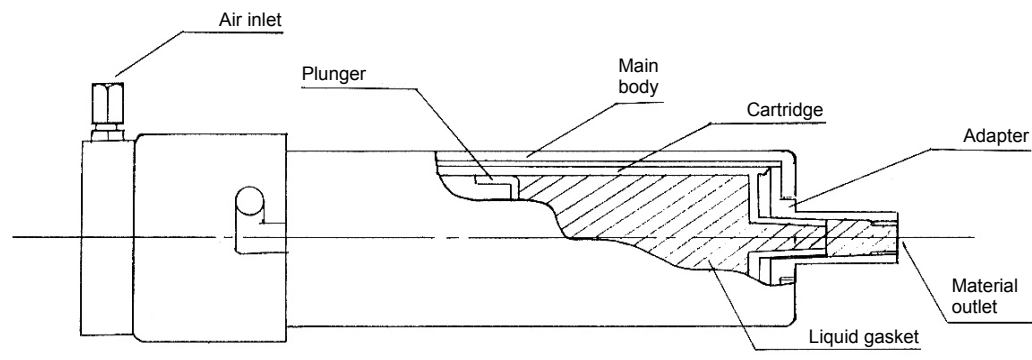

Figure 4. Cartridge tank made of plastic

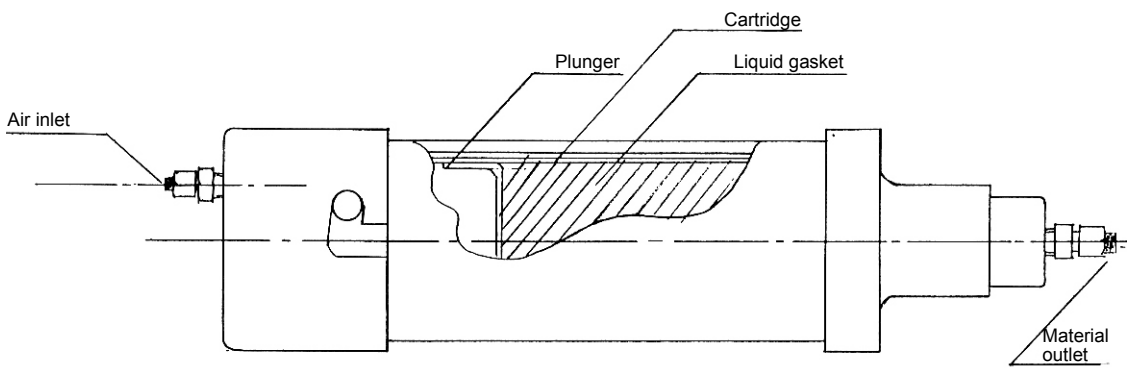

Figure 5. Cartridge tank made of aluminum

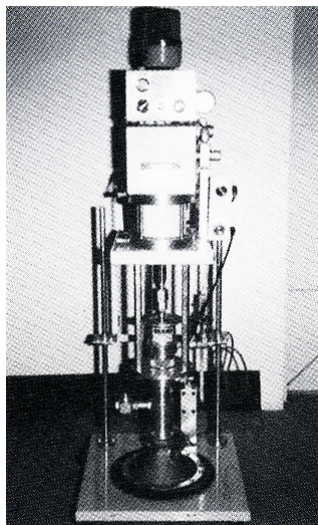

Photo 9 Power booster with residue detector

3-4 Types of valve and the characteristics

The valves that open or close dispensing liquid gaskets are one of the most important coating equipment components. The following three types are most commonly used:

Table 7

Type	Pinch valve	Needle valve	Poppet valve
Shape	See Figure 6.	See Figure 7.	See Figure 8.
Applicable materials	Low viscosity (10,000 cps) Organic solvent type, aqueous type, and anaerobic type.	Usable from low- to high-viscosity (up to 300,000 cps) materials. Organic solvent type, aqueous type, and silicone type.	
Pressure resistance	5 kg/cm ² or less	160 kg/cm ² or less (Custom-made products for high pressure are available.)	120 kg/cm ² or less
Operating method	The tube is pinched with the roller attached to the fore-end of the single- or dual-action cylinder.	Driven by the built-in dual-action air cylinder. Material is dispensed by pull-in of the rod.	
Durability	Number of pinches: 100,000 times	Number of strokes (Requires retightening of the sliding component packing.)	300,000 strokes
Dispensing volume adjustment	Adjusts the constriction of the pipe line with the built-in flow-regulating valve.	Increasing or decreasing of pipe line resistance at the valve seating section, with stroke control.	
Material for valve seat	Thin-wall Teflon tube	Teflon block	Teflon O-ring
Features	Suitable for anaerobic materials that should not be contacted to metal parts, since all parts contacting the material are made of Teflon. High dispensing response Easy cleaning of inner part	Suitable for high-pressure feeder and dispenser of highly viscous materials (because valve seat sealing is ensured by material pressure.). Large volume dispensing is possible by enlarging the orifice.	When cobwebbing occurs, the material can be drawn into the nozzle by the reverse-suction effect. Diameter of the orifice is restricted. Suitable for small volume dispensing.
Cautions for use	The tube will withstand a limited number of pinches and may be difficult to clean and replace after broken failure. Therefore, it is recommended to provide a counter to monitor the number of pinches. If making open-close speed of the valve variable with speed controller set on each port of the air cylinder for operation, it allows constant width coating with dispensing volume control at the beginning and the end.	Since these types are often used at high pressure, It is necessary to pay attention on material leaks from the packing of sliding parts. If leakage occurs, immediately retighten the part. Note that some grades of liquid gaskets may accelerate wear of sliding parts.	

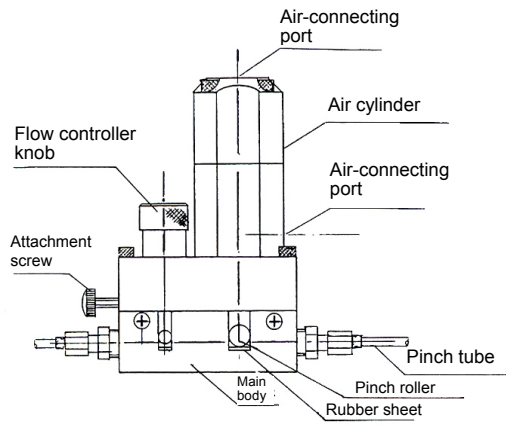

Figure 6. Pinch valve

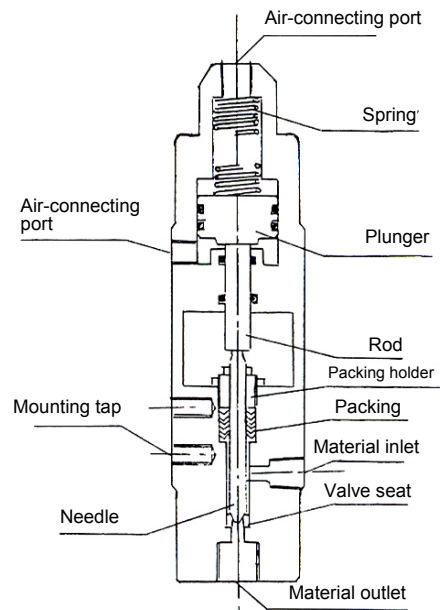

Figure 7. Needle valve

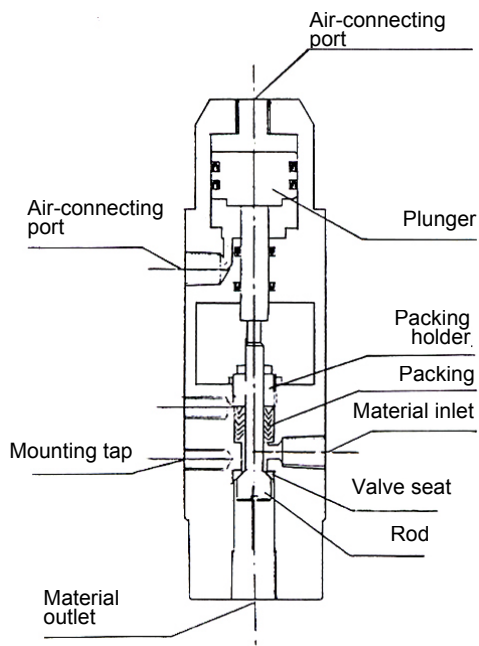

Figure 8 Poppet valve

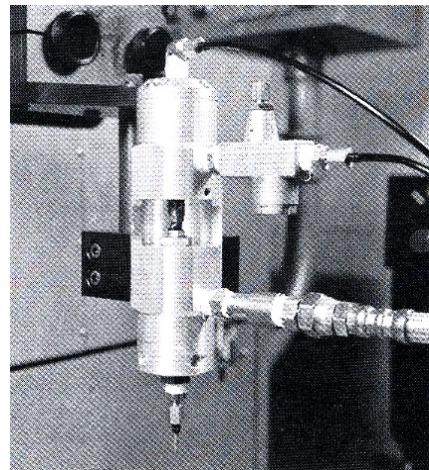

Photo 10 Poppet valve

3-5 Types of non-standard components and the characteristics

The following non-standard components are used to improve the usability of coating equipment. They are not essential, and it is recommended to decide its adaptation upon scrutinizing the justification of usage and cost.

Table 8

Section	Component types	Descriptions
Main body stand	Safety shutter, safety door, safety cover	These components are incorporated into moving parts such as the nozzle-driving section, loader, and unloader to ensure operator safety. Selection is generally based on user safety standards.
	Work piece sensor	Sensor that detects whether the work piece is set to the jig. Proximity switches or photoelectric switches are used. In general, loading and dispensing are not performed when no work piece is present.
	Work piece type sensor	This is a device to sense type of work piece and, by using the signal, select a pattern for nozzle driving section.
	Work piece orientation sensor	This sensor determines whether the orientation of the work piece set to the jig is correct. Horizontal detection is particularly important to avoid interference with the nozzle.
	Work piece loader and unloader	These are provided to prevent any part of the operator's body from entering the driving range of the nozzle and to facilitate work piece setting. Work pieces are generally moved horizontally or vertically. Ejector from the jig may be set.
Nozzle - driving section	Automatic exchange mechanism for template	While template type is not good for interchangeability of pattern, in some pattern profiles, automatic switching is possible. Following show the methods. By sliding two templates By reversing two templates By adding to the standard template.
Head section	Flow control valve	Although flow can be controlled with adjusting the valve stroke, the resulting control range can be inadequate. Since flow control valves are allowed to use on high pressure, and light weight and compact it can be mounted at the material inlet of the valve and adjusted easily with dialing.
	Shock sensor	Used to automatically halt the nozzle-driving section when the nozzle strikes a work piece or other object. Incorporates a switch that operates at low load.
	Solidification prevention cap for nozzle	If the coating equipment is not used for extended periods, the tip of the nozzle is covered with a cap to prevent solidification. The cap may contain solvents. Take care not to operate the equipment with the cap attached. The nozzle may interfere with the work piece or other objects.
Pressure feeder for material	Residue detector	Lack of material warning is indicated by a lamp or buzzer. Proximity switches are used for the pressure tank and cartridge tank. Limit switches are used for the high-pressure pump.
	Material regulator	When silicone type material is fed with high-pressure pump, this device is used to buffer pulsations to screen transfer of pressure fluctuations from the primary side to the secondary side. This device can be also used to regulate dispersing volume. However, the orifice will gradually narrow over time, and occasional overhaul is required to prevent clogging by dust and solidified materials.
	Material filter	When silicone type material is fed by high pressure pump, a SUS mesh filter is installed at the pump outlet to filter out foreign objects and solidified material. Requires occasional overhaul cleaning.
	Tank pressure compensator	The viscosity of viscous fluids generally varies according to air temperature. Dispensing volume of material will not be constant if operating pressure is kept constant. Particularly in winter, air temperature varies significantly during working hours in a day, and dispensing volume varies. This device is used to minimize such fluctuations by automatically adjusting the operating pressure of the pressure feeder based on the variation of the air temperature.
	Stirrer	If material that precipitates in the pressurized tank is used, this dispenses with stirring. The stirring blades are usually rotated in the tank with an air motor mounted on the cover of the tank and stir the material.
Controlling section	External memory	When computer-based nozzle driving equipment is used, additional memory is installed to the control board to increase memory capacity for patterns. Cassette tapes and bubble cassette memory modules are used.
	Voltage stabilizer	This device is attached to eliminate the effects of primary voltage variations on the secondary side when using computer-controlled nozzle-driving equipment. (Secondary side power supply is alive in the event of an instantaneous power failure.)

4. Screening method

Screen print method is applied to liquid gasket coating. This method can be used only for materials that will not solidify even left in the room temperature for long time. It is intended for use only with anaerobic materials.

4-1 Configuration of screening-type coating equipment

See Figure 9 and Photo 11.

4-2 Standard specifications for screening type

Table 9

Item	Standard specification
Power supply	200 V 3φ, 50/60 Hz, 10 A
Air supply source	4 to 6 kg/cm ²
Maximum size of screen frame	1,000 × 700 mm
Maximum size of screen	900 × 600 mm
MAX coating area	600 × 400 mm
Drive speed of squeegee	170 to 115 mm/sec (adjusted by belt tension.)
Material of squeegee	Urethane rubber
Squeegee printing pressure adjustment	Controlled by the pressure of air cylinder.
Coating time	10 to 12 sec (including loading and unloading time)
Material of screen	Blended fabric of nylon and Tetron
Durability of screen	10,000 operations (depending on the shape of the work piece)
Film thickness of screen	0.5 to 1.0 mm
Automatic feeder for material	Pressurizing with the cartridge tank; cartridge capacity: 500 cc
Other	A protection mechanism may be required for the screen, depending on the shape of the work piece.

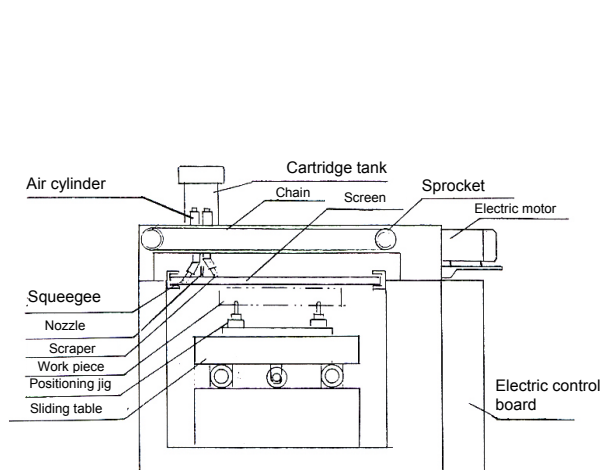

Figure 9. Schematic diagram of screening method

Screening method

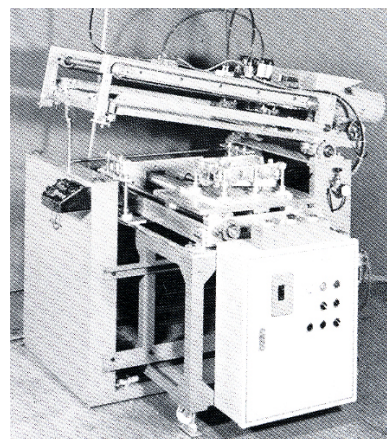

Photo 11. Screening coating equipment

5. Stamping method

The coating surface is pressed against a liquid gasket film formed uniformly on the outer surface of a box-type drum to transfer the film. Allows to coat organic solvent and aqueous liquid gaskets to a smooth flat surface of complex shape.

5-1 Configuration of stamping type coating equipment

See Figure 10, and Photo 12.

5-2 Standard specifications for stamping type

Table 10

Item	Standard specification
Power source	200 V 3 ϕ , 50/60 Hz, 10 A
MAX dimensions of drum surface	400×500 mm (There are several types differentiated by drum surface size.)
MAX tank capacity	90 L (Required minimum volume of material: 15 L)
Driving force for drum	Electric motor (An explosion-proof specification is required for the organic solvent type.)
Drum dividing method	Quadrisection Geneva
Coating surface halt time	MAX 12 sec, MIN 4 sec (continuously adjustable)
Dividing time	MAX 4 sec, MIN 1.5 sec (continuously adjustable)
Thickness of formed film	1.8 mm to 2.3 mm (adjusted by the altering the thickness of collars at both ends of the film-forming rod)
Film thickness after transfer	0.01 to 0.10 mm (depending on the viscosity of the material)
Other	<ul style="list-style-type: none"> • If the coating surface contains convex parts, concave parts are provided on the drum surface to ensure close contact. • A shutter mechanism may be provided to prevent solvent volatilization. • Organic solvent materials require the provision of an exhaust duct.

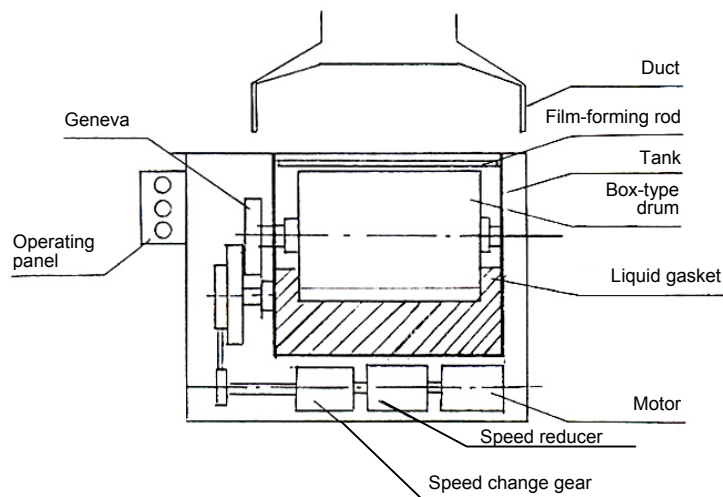

Figure 10. Schematic diagram of stamping method

Stamping method

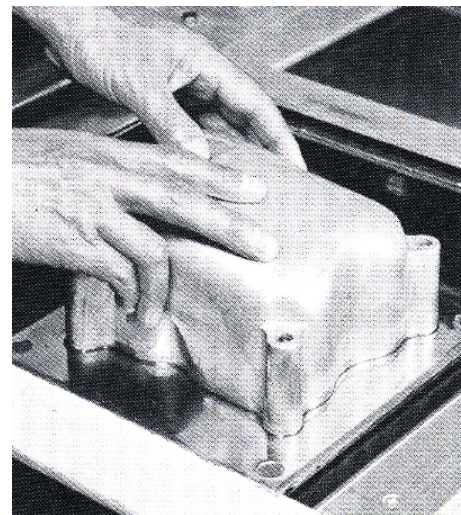

Photo 12. Stamping type coating equipment provided with shutter

6. Examples of actual coating equipment applications

Although the coating equipment described above is also used to coat liquid materials other than liquid gaskets, Table 11 describes only examples involving the coating of liquid gaskets.

Table 11

Coating method	Drive type	Material	Examples of application		
Tracing	Template	Anaerobic type	Oil pressure control unit		
		Silicone type	Transmission case for automobiles Oil pump case Thermostat case Water outlet cover OHC bearing case for motorcycles Water cylinder	FF transmission case Rear oil seal retainer Transmission rear cover Rear cover Cylinder head cover Warm air heater blower	Flywheel cover Oil pan Brake cover and shim Snowmobile crank case
	Photoelectric tube	Organic solvent type	Transmission case for automobiles	Caulked condenser joint	
		Silicone type	Gas meter counter case		
	Computer	Aqueous type	Lower case for motorcycles	Upper case for motorcycles	
		Organic solvent type	Asbestos gasket	Lower case for motorcycles	
		Silicone type	Vertically split transmission for automobiles Oil pan plate Oil pan for agricultural machinery	Baffle plate Oil pan Gear case	Cylinder block Transmission for four-wheel light car Bathroom vanity
	Disk	Aqueous type	Steering for automobiles		
		Silicone type	Differential case for automobiles	Large differential case	Differential case for light four-wheel car
	Screening		Anaerobic type	Transmission case for automobiles	
Stamping		Aqueous type	Lower case for motorcycles	Crank case for motorcycles	Pump case
		Organic solvent type	Lower case for motorcycles Transmission case for automobiles Gas meter case	Crank case for motorcycles Transmission case for agricultural machinery	Engine cover for outboard engine

Contents of the next issue

"Boundary lubrication and lubricants"

Seiichiro Hironaka, Doctor of Science
Tokyo Institute of Technology

1. Introduction
2. Boundary lubrication mode
3. Abrasion in boundary lubrication
4. Formation of lubricating film
5. Solid lubricants
6. Friction modification

Products of chemical technology

The basic line of Pando Series products was first introduced in July 1957. The product line now includes 70 products. We plan to continue adding new products of the highest performance and quality to the Series to meet market needs, focusing on the following areas: (1) adhesives; (2) sealing compounds; (3) lubricants; (4) rust inhibitors; (5) cleaning agents; (6) coating materials; and (7) repair materials.

If you have any questions about the Pando Series, please don't hesitate to contact our sales representatives.

PANDO 192A

Rubber Grease



Rubber grease of aerosol type used when assembling rubber parts. The grease doesn't corrode rubber or plastic parts and can be used without worrying about degradation. Suitable for assembling brake master cylinders, brake wheel cylinders, clutch master cylinders, and clutch release cylinders, as well as rubber parts such as O-rings. Excellent lubrication properties facilitate easy and reliable assembly.

PANDO 391A

Spray Gasket Remover



Removing stuck gaskets is arduous and unpleasant. 391A quickly and easily removes difficult-to-remove stuck gaskets and packing. 391A is sprayed to enable simple, easy removal. Just spray 391A on the gaskets or packing to be removed. They will swell in two to three minutes, at which time you can peel them off with an appropriate tool, like a spatula.

PANDO 614B

Non-stick Protective Material



PANDO 614A is a non-stick aerosol protective material that forms transparent films that are easily peeled off when necessary. It can be used to protect products and to prevent breakage, rusting, and damage during transportation of machinery, devices, parts, plastic products, and glass products; to protect polished or plated surfaces of various metals; and to protect against rust and staining of ventilation fans, skis, skates, golf clubs, bicycles, and carpenter tools.

PANDO 691A

Butyl Sheets for Sheet Metal Working

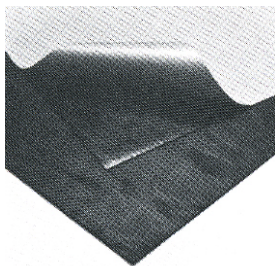

Sound-insulating and vibration-isolating material based on butyl rubber. Since the sheets are coated with adhesives, they are easily applied to broad areas. The 1.5-mm thick sheets offer excellent sound-insulating and vibration absorption performance.

Apply to thin steel sheets used in vehicles, electrical machinery, building materials, and plant facilities to reduce vibration and impact noise.

PANDO 182A

High Viscosity Spray Grease



PANDO 182A is an aerosol rust proof lubricant. A film of greasy lubricant forms immediately after application. This film resists running or dripping and remains in place for extended periods, ensuring excellent lubrication and rust-prevention properties. PANDO 182A offers excellent low and high temperature resistance and water resistance. It will not drip or run at high temperatures, and remains in place even when exposed to rain.

Product Introduction: Pando Series

PANDO 661B

Anti-friction Composition for Engine Oil



PANDO 661A is added to engine oil to reduce wear at various areas within the engine. Molybdenum disulfide and graphite offer superb lubrication. Fine particles of these compounds form strong, smooth, heat-resistant lubricating films on sliding surfaces, ensuring lubrication over extended periods of use.

PANDO 660A

Engine Conditioner



Just inject PANDO 660A into the carburetor to remove carbon deposits and renew engine performance. No need to disassemble the carburetor, suction line, and combustion chamber. When injected, this cleaning agent forms foam that allows the agent to adhere to wall surfaces without running off, maintaining cleaning power. Cleaning is simple and effective compared to other liquid cleaning agents.

PANDO 158A

Spray Adhesive



An aerosol adhesive containing acrylic resins as major components. Simply spray PANDO 158A to the surfaces to be joined to mount posters, labels, stickers, carpets, artificial lawn, flooring material, wall paper, heat insulating material, acoustic material, or cushioning materials. PANDO 158A works with polyethylene, polypropylene, fluorine resin, and silicone resin, surfaces that normally resist adhesives.

PANDO 661A

Dewatering Agent for Gasoline Tank



PANDO 661A is a dewatering agent for gasoline tanks that disperses the water that tends to accumulate over time in gasoline tanks. Just pour the agent into the gasoline tank. This disperses water in the gasoline tank and fuel system to prevent engine stalling; prevents water freezing in the gasoline tank and fuel system to allow smooth engine starts; prevents corrosion caused by water; and cleans the inside of the carburetor to maximize fuel efficiency.

PANDO 614A

Zinc-rich Spray



A high-concentration aerosol zinc dust paint containing zinc dust and epoxy resins as major components. Unlike conventional rust proof paints, PANDO 614A prevents rusting by initiating electrochemical reactions between zinc and iron, even when flaws are found on the painted surface. PANDO 614A is used to inhibit rust on bridges, tanks, outer surfaces of pipelines, guard rails, poles used for traffic signs, steel structures, steel towers, vehicles, water tanks, and ship decks. Also used to inhibit corrosion on zinc roofing, veranda, gates, fences, rainwater gutters, sheds, and wash-line poles for household use.

PANDO 612A, 612B

Heat-resistant Paints for Muffler



These are heat-resistant paints for mufflers, composed primarily of heat resistant synthetic resins. Used on automobile manifolds, exhaust pipes, catalytic converters, mufflers, plant equipment exposed to high temperatures, stoves, chimney stacks, boilers, and incinerators. These paints withstand low temperatures as well as peeling and cracking caused by vibration and shock, helping to maintain cosmetic characteristics over extended periods of use.

Information on Research and Development

Completion of Three Bond Research Center



To enhance its research and development capabilities, Three Bond has built a Research Center at its headquarters site.

The building is a reinforced concrete structure with three stories above ground and one level underground. Gross floor area is about 4,500 m², about three times that of the previous Research Center. Among the most advanced facilities newly introduced are a fully sound-isolated engine test room, impulse fatigue testing machine, and state-of-the-art analyzers.

In addition to research and development on new products and technology systems, Research Center is responsible for various research contracts and collaborative projects involving customers and universities, as well as technical training and trial work for domestic and overseas members of the company group. It also exhibits production processes via model plants and laboratory tours to foster a deeper understanding among visitors of the quality and characteristics of our products. These services are available 24 hours a day, every day of the year.

If you happen to visit Tokyo, please visit our Research Center in Hachioji and take advantage of all the benefits offered by the facilities. All of us at the institute look forward to serving you!

* * *

◆ Inner courtyard of Three Bond Research Center: "Garden of Creation" ◆ _____

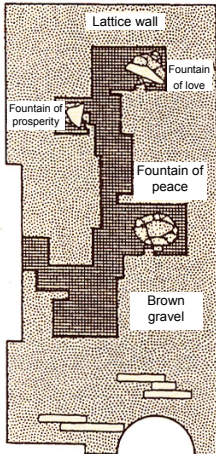

We named this space the Garden of Creation to express the outlook of our researchers. The innovations that contribute to society emerge through creative efforts. We believe that theory, inspiration, and passion are the three essential elements of creation.

Lattice wall (theory): The orderly attitude of theory is expressed by the lattice design.
Brown gravel (inspiration): The brown gravel laid all over the courtyard expresses unbounded inspiration. Each grain of gravel has a specific and distinct shape, as though embodying a special essence that might inspire those willing to look closely enough.

Three stones, collectively symbolizing energy and passion and individually representing the following ideals:
 (1) Fountain of love,
 (2) Fountain of prosperity, and
 (3) Fountain of peace.

Like a pouring fountain, the whole represents an unbounded energy and passion. One surface of each of "Love" and "Prosperity" is polished with wet rubbing. Two stones are placed to form a triangle of light with the third stone, "Peace," at the apex. This configuration is intended to express the infinite energy and passion that results from binding "Love" and "Prosperity" to "Peace" with a thread of light.

Illumination (unexpected wonderment):
 Illumination suggests that unexpected wonderment results when a object is illuminated.



THREE BOND CO., LTD.

1456 Hazama-cho, Hachioji-shi, Tokyo 193-8533, Japan
 Tel: 81-426-61-1333