

RFM-E22

Elektrikli Radial Komponent Kesme Bükme Makinesi



I. Packing List

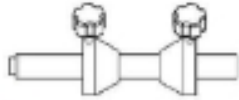

Fig.1

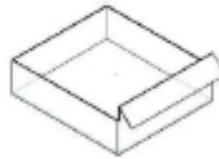

Fig.2



Fig.3



Fig.4

NO	Attachment Name	Unit(Parts/Sets)
1	Host	1
2	Hex Wrench	1
3	Hanging Rod	1
4	Support Rod	1
5	Manual	1
6	Material Box	1

RFM-E22

Elektrikli Radial Komponent Kesme Bükme Makinesi

I. Packing List

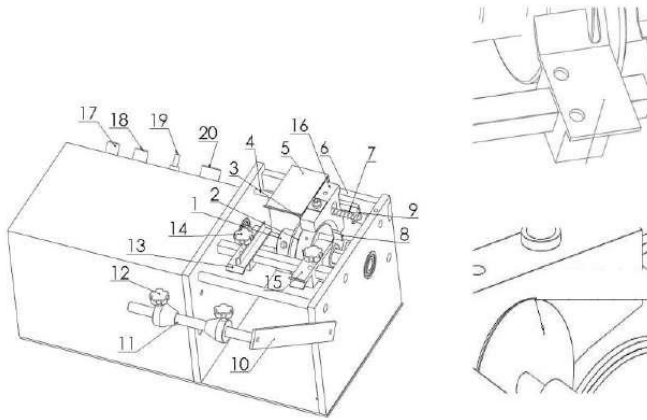

	L	3-20mm
	W	0.4-1.0

1.Knurler Kesici	11.Kesme Çubuğu
2. Asma Çarkı	12. Ayar Döneri
3. Dairesel Kesici	13. Çıkarıcı
4. Dairesel Kesici Şaftı	14. Ayar Döneri
5. Kapaak	15. Besleyici
6. Kapaak Oturma Sabitleme Rodu	16. Kapaak Tutucu
7. Yay	17. Sigorta
8. Döner	18. Göstergesi
9. Altıgen Vidası	19. Anahtar
10. Destek Rodu	20. Gözetim

RFM-E22

Elektrikli Radial Komponent Kesme Bükme Makinesi

2. Cut a small section of braided capacitor. Then hang the small hole on the braided capacitor the hanging round.
3. Loosen the knob on the feed clip. Then insert the taping capacitor (tape) into the track of the feed clip. So that each small hole can be aligned with the round pin on the hanging round. But it cannot be shaken too much from side to side. Finally, twist the knob.
4. Loosen the knob on the holder. Then move it to the other side of the holder near the capacitor. So that the braid can't move left and right. But can slide back and forth. Then tighten the knob.
5. Loosen the adjusting screw on the fixed shaft of the round knife (8) in Fig. 4 to loosen the spring. So that it can slide. Then loosen the fastening screw on the knurled cutting knife in (1) Fig. 5 and move the knurled cutting knife in the axial direction to the required length. Then adjust the spring on the circular knife fixing shaft to properly push the spring so that the circular knife is close to the inner end face of the knurled cutter, and tighten the adjustment screw.
6. Attach the cover.

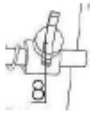

Fig.4

Fig.5

VII. Attention

1. Please do not touch the transmission parts with your hands when the machine is rotating. So as not to get your hands and clothes caught in. To achieve the aim "civilized production, safety first".
2. When it is found that the braiding section deviates from the round pin of the hanging tooth, it should be stopped immediately to correct it.

VIII. Equipment Maintenance

1. Hanging material wheel, knurled cutting knife, the surface of the round knife should not be stained with oil. And other transmission parts or parts can be added with appropriate anti-rust oil to achieve anti-rust effect.
2. Check whether the screws of each part of the machine are loose and tighten them if there is looseness.

The residual waste on the machine should be cleaned after going to work every day and themachine is in good condition at all times.

